

## Blueskin® Weatherbarrier

### Product Information

Stop Water Damage

**Weatherize Your Building with Blueskin®**

Self-Adhering / Self-Sealing / Flexible Flashing Membrane

Blueskin is manufactured to achieve the highest adhesion level possible. When applied properly, it will virtually eliminate drafts and water leaks at critical areas around the exterior of your residential or commercial building. The membrane is made of an SBS rubberized asphalt compound that is integrally laminated to a (blue) cross-laminated, polyethylene film, and is specially designed to be self-adhered to all prepared substrates of concrete, CMU's, primed steel, rigid vinyl, mill finish and anodized aluminum, galvanized metal, dry-wall, plywood, and OSB sheathing. The SBS membrane is flexible with excellent adhesion at low temperatures.

Blueskin is impermeable to air, moisture vapor, and water; and is self-sealing when penetrated with most fasteners.

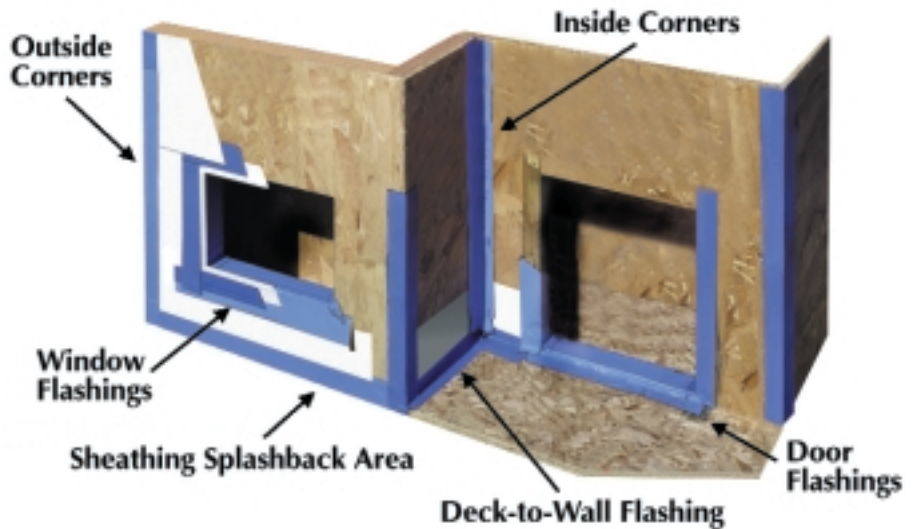

### Areas Blueskin Can Make the Difference

- Window and Door Flashing
- Flashing around Skylights, Roof Vents, and Chimneys
- Separator Sheet for Wood-to-Wood and Wood-to-Concrete
- Tie In Metal Flashing to Dissimilar Products
- Tape Sheathing Joints
- Behind Vinyl Siding Inside and Outside Corner Trims

**Window Rough Opening Flashing Guidelines**

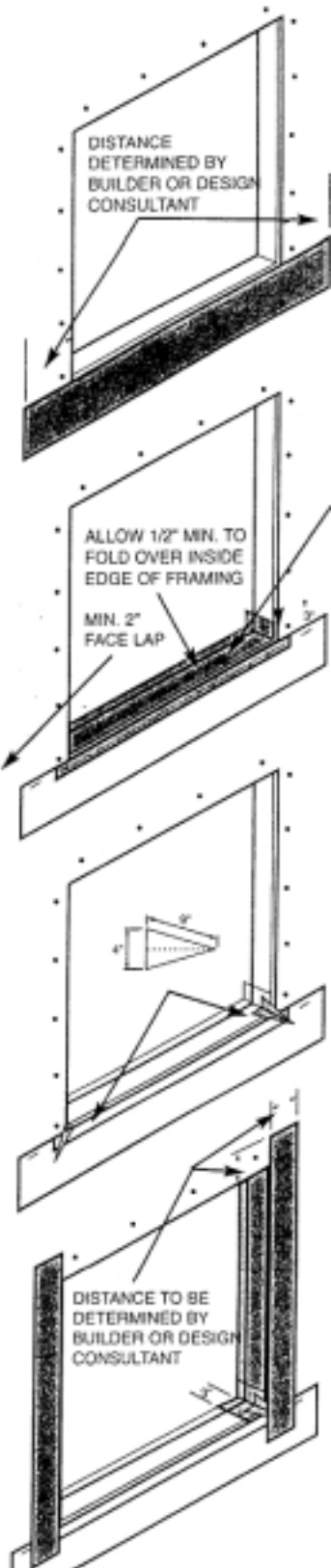

1. Install Blueskin per diagram, leaving release paper on back side of Blueskin, place paper side against sheathing and attach by stapling or nailing along top edge.

2. Cut Blueskin the width of window rough opening plus 6". Align per diagram. Remove release paper and adhere.  
For additional attachment, staple along top of jamb edge and 1/2" edge folded over framing. Do not staple anywhere else. Allow 3" minimum to cover up both jambs.

3. Cut Blueskin wing pieces per diagram. Fold in half lengthwise. Remove release paper. Center over sheathing. Insert into sill/jamb inside corner, adhering to jamb and sill. Fold remaining Blueskin over and adhere to sill face pieces.

4. Install Blueskin jamb pieces per diagram, adhering to sheathing and framing.  
For additional attachment, staple perimeter edges above sill area.  
Upon completion of Steps 1 through 4, using a J-roller, apply pressure and roll entire surface of Blueskin to remove wrinkles and air pockets.

5. Install flanged window per window manufacturer's installation instructions.

**Window Rough Opening Flashing Guidelines**

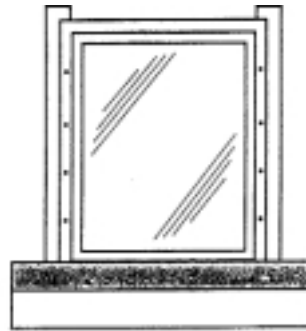

6. Install Blueskin per diagram, adhering to the window sill, nailing flange and the Blueskin installed in previous steps.

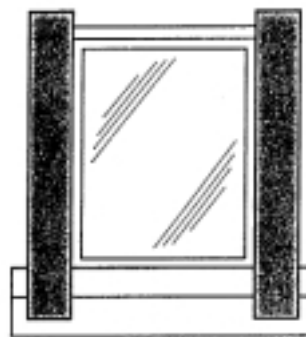

7. Install Blueskin per diagram, adhering to the window jamb, nailing flanges and the Blueskin installed in previous steps.

Note: Prior to installing this step, consult with builder or design consultant on how to interface with building wrap.

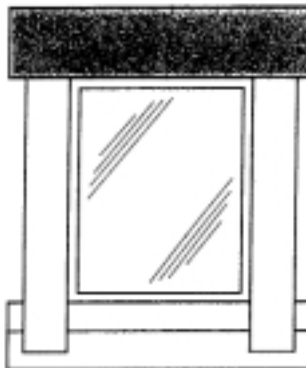

8. Install Blueskin per diagram, adhering to the window head flange and sheathing.  
Upon completion of Steps 6, 7, and 8, using a J-roller, apply pressure and roll entire surface of Blueskin to remove wrinkles and air pockets.

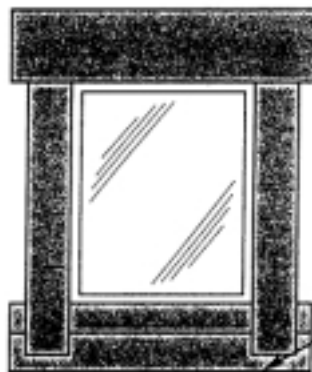

**Visual of Completed Assembly**

Consult with builder or design consultant on how to interface building wrap at jambs and head.

BUILDING WRAP TUCKS UP UNDER BLUESKIN INSTALLED IN STEP ONE.

## Wrapping Windows and Doors Properly Now Protects a Building Later

It is the painstaking details homeowners never see that count the most.

Seldom do the materials hidden from the light of day get the credit they deserve until something goes wrong. This is especially true for the wrap installed around windows, doors and rough openings.

Residential building wrap and flashings play a critical role in diverting air and moisture away from a home's sheathed substrates. Regardless of the cladding, if these materials are not used or not properly installed, the opportunity exists for moisture to find its way into places it does not belong.

To avoid this problem when applying exterior insulation and finish systems, Senergy requires contractors to use Senerwrap around doors, windows, and any structural openings. This secondary weather barrier should also be applied over the building wrap where the walls meet the foundation, decks, and other walls; along the chimney lines; and any area where splash-back could be a problem.

The 20-mil-thick composite membrane is packaged in 9-inch-wide by 150-foot-long rolls and sold nine rolls per carton. The self-healing, self-adhesive wrap should only be installed over manufacturer-approved substrates and surfaces. With the exception of steel framing and building paper, all other approved surfaces require Senergy's flashing primer to be applied before Senerwrap is adhered to the substrate.

"If wood framing, masonry, or Dens-Glass Gold are being used, they must be primed first. Otherwise, Senerwrap will not stick to the surface," said Randy Donovan, Senergy's director of technical services.

In order for Senerwrap to work effectively, Donovan said it must be applied in the correct sequence of other building materials that will come into contact with it. Using a window as an example, the contractor must first cut the house wrap and fold the material around the window's rough edges and into the window opening. When cutting through the building wrap, the contractor should run the utility knife across the top of the window opening, making a horizontal cut.

Next, an inverted Y should be sliced down the middle. After the window opening is wrapped at the sill and jambs, it must be sealed at the corners. Strips of Senerwrap should then be installed up behind the building wrap on the jambs and over the building wrap at the sill.

Donovan said that when applying Senerwrap or building wrap, contractors must overlap it a minimum of 2 inches horizontally and 6 inches vertically. This technique ensures that any incidental moisture will have a clear drainage path so water travels over the building wrap and outside the wall.

Following the window's installation, Senerwrap is then placed along the window head, underneath the building wrap, and taped at the corners. Because Senerwrap is self-adhesive, there is not need to use staples.

Ron McClure, president of a Charlotte, N.C.-based consulting firm that provides construction failure analysis, stressed that wrapping windows and doors is a good construction practice, but the process should be taken one step farther. A retired builder with 28 years in the construction business, McClure said applicators must also make sure all windows and doors are head- and pan-flashed to direct water outside the walls. "You cannot solely depend on a barrier wrap," he said, "For example, you must flash the window to the outside because you must assume that a window has the potential to leak internally.

McClure said areas of concern are at roofs, windows, doors, and joints between frame structure and exterior landings, decks, or stoops. He emphasized that all barrier material must be flashed to terminate at the face side of the building material. "Whenever barrier material is being used, it is critical that it be installed to provide complete protection to the frame structure independent of the cladding material itself.

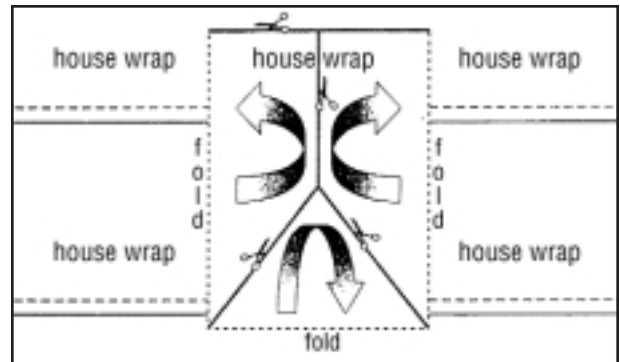

**House Wrap before Windows, Outside**

A. Cut the house wrap horizontally across the top of the window opening and then make an inverted Y-cut down the middle. Fold the wrap at the sill and jambs. Seal at the corners.

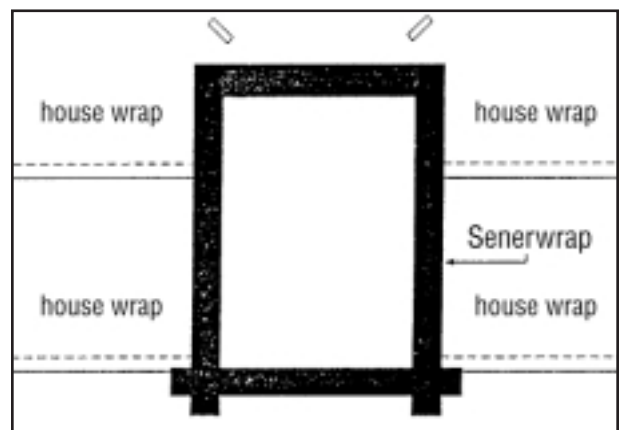

**House Wrap before Windows, Outside**

B. Install Senerwrap along the sill and jambs, making sure it overlaps a minimum of 2 inches horizontally and 6 inches vertically. The house wrap should also be overlapped.

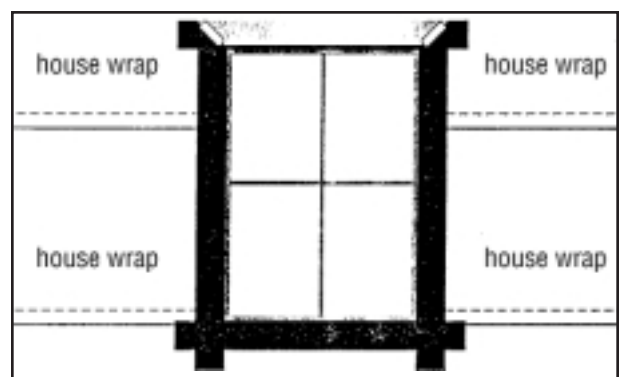

**House Wrap after Windows, Outside**

C. After the window's installation, install Senerwrap at the top of the window. Next, fold the house wrap over the Senerwrap at the top of the window and tape at the folded edges.